

DETAIL A : KERB DETAIL

1:8

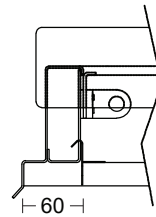

QUALITY & LOCATION OF SPRINGS VARIES WITH SIZE

DETAIL B: SPRING DETAIL

1:10

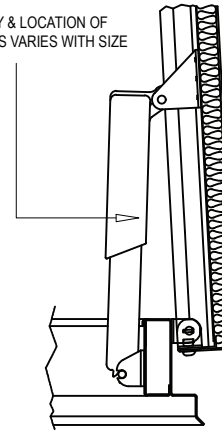

QUALITY & LOCATION OF SPRINGS VARIES WITH SIZE

PLAN 1:20

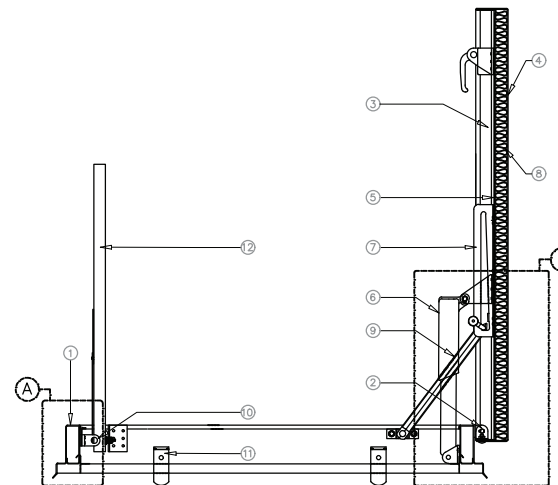
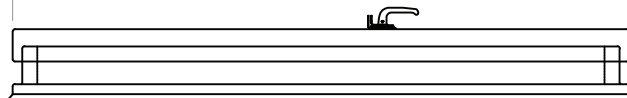

SPECIFICATIONS

1. ALUMINIUM FRAME W/FLASHING
2. STAINLESS STEEL PINTLE HINGE
3. 15 x 50mm EPDM GASKET (ALL ROUND COVER)
4. ALUMINIUM COVER GAUGE
5. ALUMINIUM COVER LINER
6. LIFTING MECHANISM WITH METAL TUBES AND COMPRESSION SPRINGS
7. ARM GUIDE BRACKET
8. 25mm THICK FIBERGLASS COVER INSULATION
9. HOLD OPEN ARM W/ METAL GRIP
10. LOCK STRIKE & PADLOCK HASP
11. STAINLESS STEEL ANCHOR TABS (QTY & LOCATION VARIES W/SIZE)
12. MS FOLDABLE HOLDING POST (L = 760MM)
13. MS HANDRAIL
14. SLAM LATCH



+6012 - 392 8447

salesbronteattic@gmail.com

bronteattic.my | BRONTE ATTIC (M) SDN BHD

bronteattic.sg | BRONTE ATTIC MARKETING

thaibronteattic.com | BRONTE ATTIC (THAILAND) CO., LTD

ROOF HATCH

MODEL

RHA 0816