

PLAN 1:10

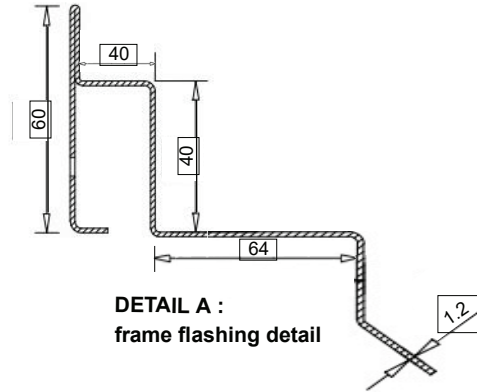

DETAIL A :
frame flashing detail

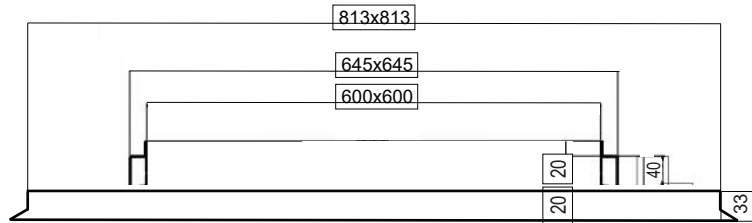

ELEVATION A 1:10

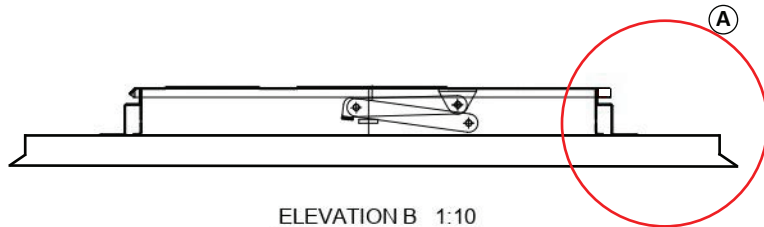

ELEVATION B 1:10

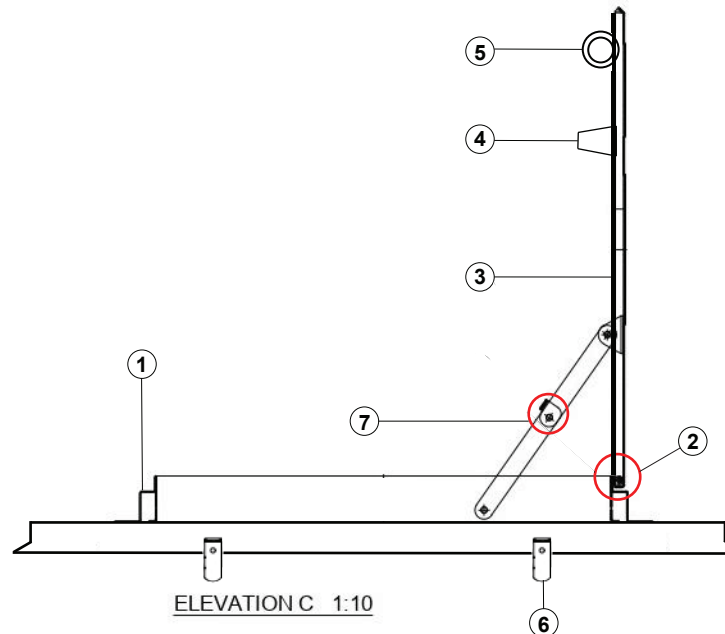

ELEVATION C 1:10

SPECIFICATIONS

MATERIAL

Stainless Steel 201

DIMENSION (OPENING SIZE)

600 x 600 mm (Internal Frame Opening)

WEIGHT

22KG

MATERIAL THICKNESS

Lid: 2.0 mm

Base Frame : 1.5 mm

1. FRAME W/FLASHING
2. STAINLESS STEEL PINTLE HINGE
3. FOAM GASKET (ALL ROUND COVER)
4. ALUMINIUM COVER GAUGE
5. PADLOCK HASP
6. STAINLESS STEEL ANCHOR TABS
7. HOLD OPEN ARM



+6012 - 392 8447

salesbronteattic@gmail.com

bronteattic.my | BRONTÉ ATTIC (M) SDN BHD

bronteattic.sg | BRONTÉ ATTIC MARKETING

thaibronteattic.com | BRONTÉ ATTIC (THAILAND) CO., LTD

ROOF HATCH

MODEL

SAC 0606

(STANDARD SHOPDRAWING)

INSPECTION MAINTENANCE

Visual inspection for any damage or loose fixings must be done periodically and prior to use. No certified maintenance is required. Basic wear and tear preventative maintenance is recommended as per manufacturer, specifications recommendations.